

**MTX**<sup>®</sup>  
**AUDIO**

**JACK**  
**HAMMER**

24



**OWNER'S MANUAL**



## RECOMMENDED ENCLOSURE REQUIREMENTS

### For Sealed Enclosures

The JackHammer requires a volume of 5.47 cubic feet (net) per woofer. The woofer's displacement is 2.06 cubic feet. The total gross volume will be 7.5 cubic feet.

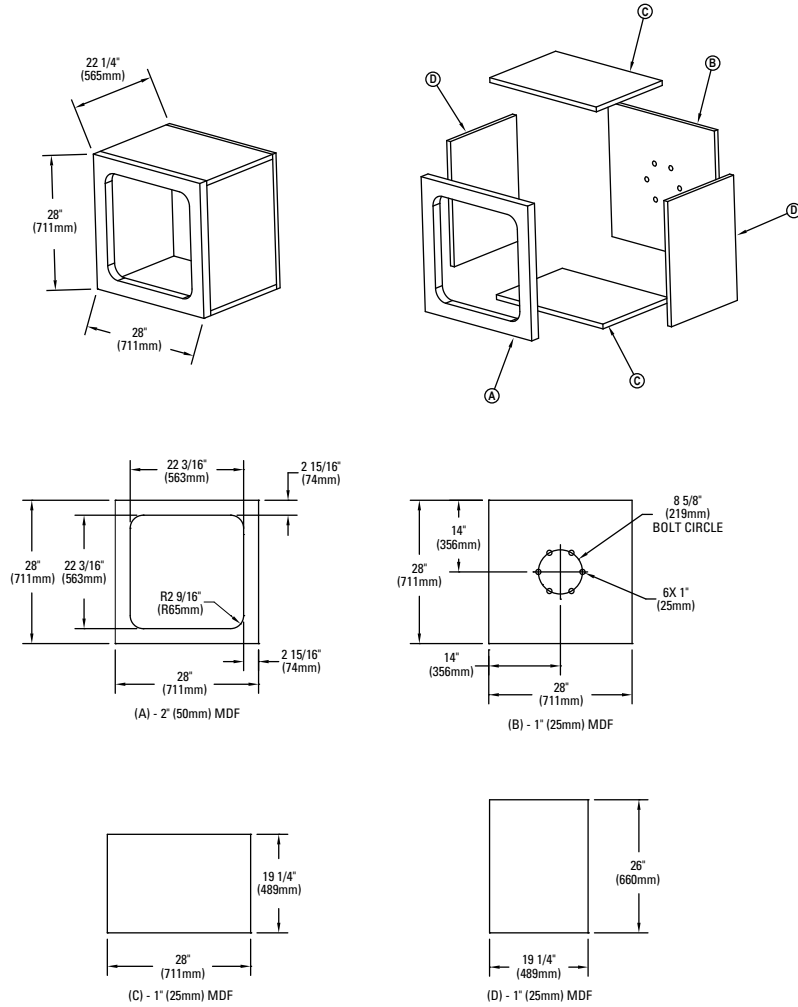

Additional ranges of sealed volumes greater than 7.5 cubic feet can be used.

### For Vented Enclosures

The JackHammer requires a volume of 10.2 cubic feet (net) per woofer. The woofer's displacement is 2.06 cubic feet. The port's internal dimensions are 26" x 5" x 15" and it takes approximately .5 cubic feet. The total gross volume will be 12.3 cubic feet.

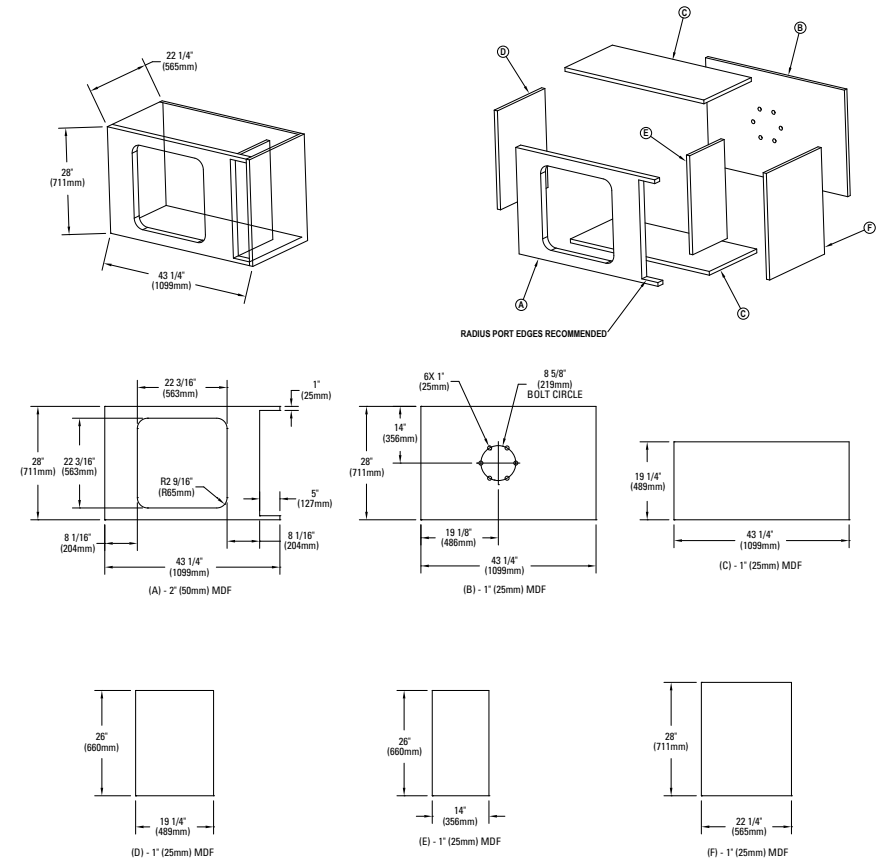

The final tuning frequency is 29Hz.

## MOUNTING

Mounting the TS9924-22 JackHammer is nothing that can be taken lightly, quite literally. You need to follow the steps below carefully and have all the necessary equipment. You will need to be able to lift the nearly 400 lbs. subwoofer comfortably. MTX Audio recommends a fork lift or engine hoist for safe installation.

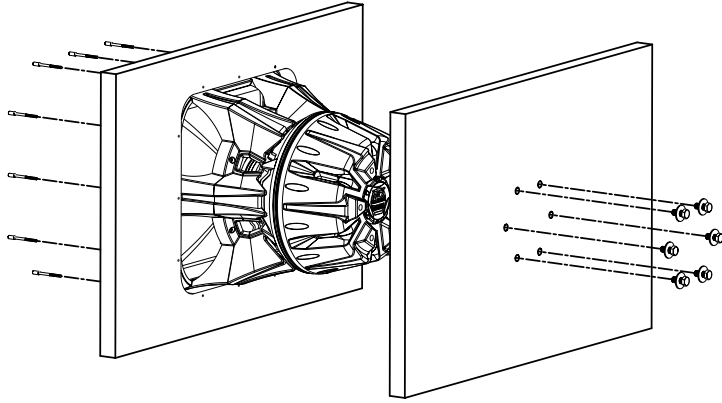

The woofer is designed to distribute its weight evenly throughout the entire structure. This is accomplished by including rear motor mounts with  $\frac{3}{8}$ "-11 bolts so it is mounted from both the front and the back. It is important that both these sides are mounted properly to ensure proper weight distribution. The drawing above shows the rear mounting hole detail for the back support. The holes are located on an 8  $\frac{3}{8}$ " bolt circle, meaning the holes are located on a radius of 4  $\frac{3}{16}$ " from the center point. Use the pallet from the JackHammer packaging to make a mounting template if needed. For the recommended 1" baffle, the bolts needed should be  $\frac{3}{8}$ "-11 threaded bolts 1  $\frac{3}{4}$ " long. Washers should be used with the  $\frac{3}{8}$ "-11 bolts to be sure there will be no air leaks around the bolts.

In the gasket of the woofer, there are four eyelet rings. Make sure they are screwed in securely before attaching a chain between them for lifting. Use one tine of the fork lift to lift the JackHammer with the chain then slowly lower it into the enclosure. Unscrew the eyelets and align the woofer with the front and rear mounting holes, and then fasten it using the screws and bolts provided. Remember to pre-drill the screw holes using a  $\frac{1}{2}$ " drill bit. Then, lift the enclosure, complete with JackHammer, into the back of the vehicle.

**Note: This unit is EXTREMELY heavy! Make sure everyone is clear and out of the way in case something should break or fall!**

**Note: MTX Audio is not responsible for damages occurred during installation. For custom installation help or answers to further questions, please call 1-800-CALL-MTX.**

**Warning: Prolonged exposure to high sound levels can lead to permanent hearing loss. In addition, drastically over powering speakers can result in extreme heat which could cause a fire. For your own safety and enjoyment, please follow the manufacturer's power handling recommendations.**

**Warning: Sudden stops or auto accidents may cause speakers to dislodge and become projectiles. Securely fasten all audio components to the car's structure to prevent property damage or serious personal injury.**

## WIRING OPTIONS

Often overlooked, the installation components used to connect the entire system need to match the maximum capability of the system or you will lose performance. MTX Audio recommends using StreetWires 4 AWG cable as the speaker wire.

### Dual Voice Coil Wiring

TS9924-22 JackHammer Superwoofers are available in a dual 2 Ohm voice coil configuration. The voice coils are labeled VC1 and VC2.

**Note: Both voice coils should always be connected.**

### Independent Voice Coil Connection Configuration

This connection is ideal when using two large mono block amplifiers per voice coil.



### Parallel Configuration

Wiring the voice coils in a parallel configuration will have a total final load of 1 Ohm. Connect each of the dual voice coil's positive terminals together so that they share the same source (amplifier). Do the same for the negative terminals. This connection is ideal when using a large 1 Ohm stable amplifier.



**Note: The wiring of the dual voice coils will affect impedance for the amplifier system. Care must be taken to assure that the resulting impedance does not exceed the amplifier's requirements.**

### Series Configuration

Wiring the voice coils in a series configuration will have a total final load of 4 Ohms.



## TS9924-22 WIRING SETUP

This figure shows the recommended amplifier connection for the TS9924-22 using the MTX TE4001D amplifier.

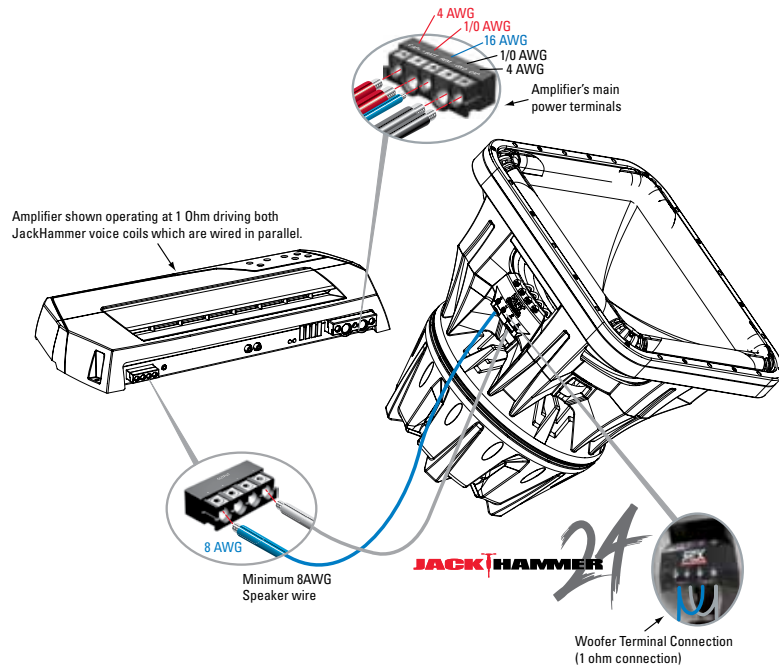

## PISTON CHANGE (RE-CONE KIT)

Since the installation of the JackHammer is a large investment in time and resources, the cone can be removed without removing the entire sub or enclosure. Re-coning the woofer is surprisingly easy. No glue is needed, just bolts, and if you followed the enclosure design it can be done without taking the woofer out of the enclosure. Directions for either procedure follow.

### To Re-cone the Woofer when Removed from the Enclosure

To remove the cone, unscrew the twelve  $\frac{3}{16}$ " hex screws from the front gasket of the woofer and remove the gasket. Next remove the six  $\frac{5}{32}$ " hex screws from the back of the spider plateau and loosen the tinsel leads at the terminal. The tinsel leads are the four 3mm hex screws at the top of the terminal that hold the voice coil wires. Gently pull on the cone under the surround and the cone assembly should pull away from the woofer motor. Be sure and pull evenly to prevent the assembly from binding in the basket. You are now ready to put in the new re-cone kit.

Place the new cone assembly into the woofer motor. Make sure to align the tinsel leads from the re-cone kit with the terminals and line up the large notches in the surround with the largest holes in the basket. Insert the tinsel leads into the terminal ensuring the red lead is going into the positive (+) position and the black lead is going into the negative (-) position. Tighten the four set screws and then slightly tug in the tinsel leads to make sure they are tight in the terminal.

Next, insert the six  $\frac{5}{32}$ " hex screws back into the spider plateau and tighten. Replace the top gasket over the surround on the top of the woofer. The counter-bore holes in the gasket need to align with the smaller threaded holes in the basket. Insert the twelve  $\frac{3}{16}$ " hex gasket screws into the counter-bored holes and tighten. Your new cone is now installed and you are ready to once again experience the JackHammer's extreme bass!

### To Re-cone the Woofer when Installed in the Enclosure

If you have made the back removable, as suggested earlier in this manual, you can remove the cone without removing the woofer from the enclosure. To remove the cone, unscrew the twelve  $\frac{3}{16}$ " hex screws from the front gasket of the woofer and then remove the top gasket. DO NOT remove the T-30 wood screws because the gasket can be removed with these still in place. Next, remove the six  $\frac{3}{8}$ " bolts from the back with a  $\frac{1}{16}$ " wrench and pull off the back of the enclosure. Then, remove the six  $\frac{5}{32}$ " hex screws from the back of the spider plateau and loosen the tinsel leads at the terminal. The tinsel leads are the four 3mm hex screws at the top of the terminal that hold the voice coil wires. Gently pull on the cone under the surround and the cone assembly should pull away from the woofer motor. Be sure and pull evenly to prevent the assembly from binding in the basket. You are now ready to put in the new re-cone kit.

Place the new cone assembly into the woofer motor. Make sure to align the tinsel leads from the re-cone kit with the terminals and line up the large notches in the surround with the largest holes in the basket. Insert the tinsel leads into the terminal ensuring the red lead is going into the positive (+) position and the black lead is going into the negative (-) position. Tighten the four set screws and then slightly tug in the tinsel leads to make sure they are tight in the terminal.

Next, insert the six  $\frac{5}{32}$ " hex screws back into the spider plateau and tighten. Replace the top gasket over the surround on the top of the woofer. The counter-bore holes in the gasket need to align with the smaller threaded holes in the basket. Insert the twelve  $\frac{3}{16}$ " hex gasket screws into the counter-bored holes and tighten. Finally, replace the back of the enclosure and re-attach the  $\frac{3}{8}$ " bolts to support the back of the woofer. Your new cone is now installed and you are ready to once again experience the JackHammer's extreme bass!



# 24



© 2009 Mitek Corporation. All rights reserved. MTX, Thunder, JackHammer and StreetWires are trademarks of Mitek Corporation. Designed and Engineered in the U.S.A.

Due to continual product development, all specifications are subject to change without notice.

MTX Audio, 1 Mitek Plaza, Winslow, IL 61089 U.S.A.

MTX003284 RevA 6/09

21A9241 AW0013198