

HIGH PERFORMANCE WOOFERS

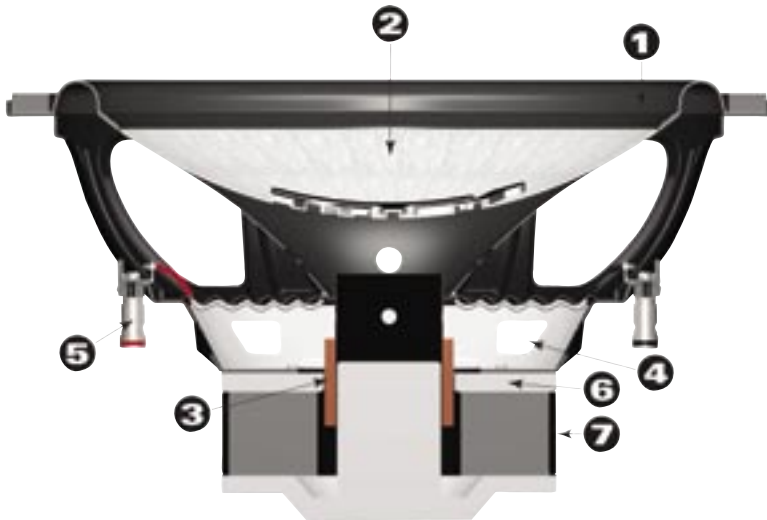

	THUNDER5500 12"	THUNDER4500 12"	ROAD THUNDER 12"
Frame Construction	16 ga. stamped steel	19 ga. stamped steel	19 ga. stamped steel
Volume Displacement (cubic inches)	44.6	26.9	26.1
Power Handling	200 - 300W	500W	400W
Xmax	.55" (14.0mm)	.32" (8.4mm)	.32" (8.4mm)
Magnet Weight	70 oz	35 oz	35 oz
Heat Sinks			
Aluminum Shorting Ring			
Magnet Boot	•		
Rubber Surround	•		
Machined Plates	•	•	
Integral Tinsel Lead	•	•	
Expanded Poly Cone Dust Cap	•	•	•
Stitched Cone	•	•	•
Spider Plateau Venting	•	•	•
Asymmetrical Linear Drive	•	•	•
Single or Dual Voice Coil Option	•	•	•
Custom Designed Enclosure	•	•	•
Industry Standard Cut Out Pattern	•	•	•
Voice Coil Diameter	1.75"	1.5"	1.5"
Voice Coil Wire Temp Rating	428° F	428° F	392° F
Voice Coil Material	Aluminum	Copper	Copper
Terminals	8 ga posts	8 ga posts	8 ga posts
PRICE RANGE	\$109.95-\$199.95	\$79.95-\$129.95	\$89.95-\$99.95
ENCLOSURE SIZE			
sealed box (cubic feet)	.75-1.5	1.0-1.4	1.0-1.4
vented box	1.0-2.0	1.75-2.25	1.75-2.25

MTX
BIGGEST
BOLDEST
BASS

THUNDER[®]
SEE THE WORLD'S GREATEST HIGH PERFORMANCE WOOFERS
AT AN AUDIO SPECIALIST NEAR YOU OR LOG ON AT
MTX.COM

MTX
AUDIO