

SUPER WOOFERS

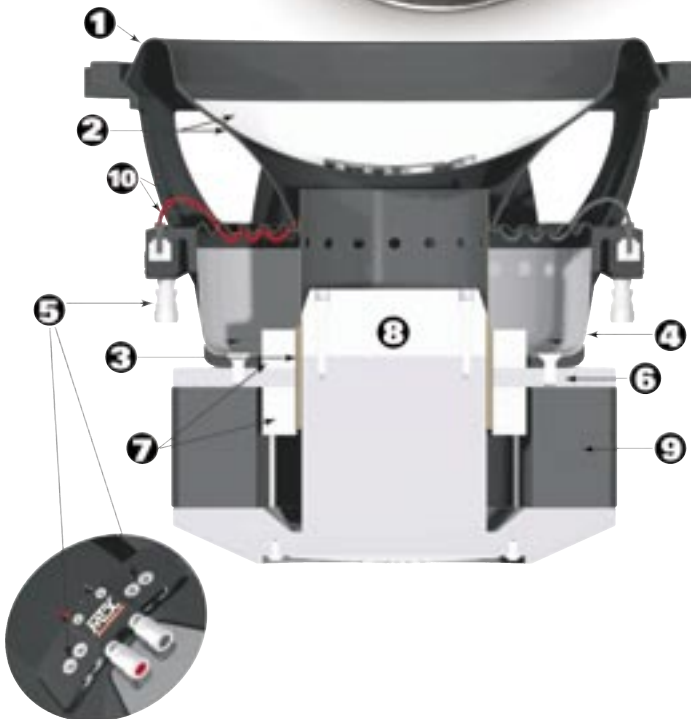

	THUNDER9500 12"	THUNDER8500 12"	THUNDER7500 12"
Frame Construction	Die-cast Aluminum	Die-cast Aluminum	Die-cast Aluminum
Volume Displacement (cubic inches)	83.4	73.6	52.3
Power Handling	1000W	500W	400W
Xmax	1.00" (25.5mm)	.75" (19.0mm)	.65" (16.5mm)
9 Magnet Weight	260 oz	120 oz	93 oz
7 Heat Sinks	•	•	•
8 Aluminum Shorting Ring	•	•	•
Magnet Boot	•	•	•
1 Rubber Surround	•	•	•
6 Machined Plates	•	•	•
10 Integral Tinsel Lead	•	•	•
2 Expanded Poly Cone Dust Cap	•	•	•
Stitched Cone	•	•	•
4 Spider Plateau Venting	•	•	•
Asymmetrical Linear Drive	•	•	•
Single or Dual Voice Coil Option	•	•	•
Custom Designed Enclosure	•	•	•
Industry Standard Cut Out Pattern	•	•	•
3 Voice Coil Diameter	4.0"	3.0"	2.38"
3 Voice Coil Wire Temp Rating	428° F	428° F	428° F
3 Voice Coil Material	Aluminum	Aluminum	Aluminum
5 Terminals	8 ga posts + double set screw	8 ga posts + single set screw	8 ga posts
Price Range	\$499.95-\$699.95	\$349.95-\$599.95	\$199.95-\$299.95
ENCLOSURE SIZE RECOMMENDED			
sealed box (cubic feet)	1.0-1.5	.75-1.5	1.0-1.5
vented box (cubic feet)	1.25-1.75	1.0-2.0	1.5-2.5

MTX
BIGGEST
BOLDEST
BASSTEST
BASS

THUNDER[®]
SEE THE WORLD'S GREATEST SUPERWOOFERS
AT AN AUDIO SPECIALIST NEAR YOU OR LOG ON AT
MTX.COM

MTX[®]
AUDIO