



RTX SERIES AMPLIFIERS



RTX3000.1 / RTX1600.4

INTRODUCTION

Congratulations on the purchase of your new MTX gear. For over 50 years MTX remains an American family-owned manufacturer full of passionate enthusiasts just like you. Thank you for counting on us to help you “Amplify The Ride”!

For best performance and longevity of your audio gear, we recommend you have your new MTX product installed by an Authorized MTX Dealer. Their installation knowledge and expertise will ensure you get the most out of your new equipment while safeguarding against potential issues. Also, please read your product warranty carefully and retain your receipt and original carton for possible future use.

We’re here to help with any installation or technical support. Visit www.mtx.com to chat, call 1-800-225-5689 to speak with an MTX Technical Support representative, or visit www.youtube.com/user/MTXAudioUSA to view product videos.

Don’t forget to register your new MTX product. Visit www.mtx.com/productregistration or scan the QR code below.

Model # _____

Serial # _____

Dealer’s Name _____

Date of Purchase _____



TABLE OF CONTENTS

2. Introduction / Safety
3. Features / Package Contents
4. Control Functions
8. Installation
11. Wiring
13. Dimensions
14. Specifications
15. Warranty

SAFETY

- Please read and follow these instructions to prevent injury and damage to the unit.
- If you are unsure about installing the system by yourself, please have it installed by a qualified MTX technician.
- Whenever working on the vehicle, it is recommended to disconnect the battery prior to starting work. Failure to do so may lead to a risk of electric shock or equipment damage.

When connecting power and ground wires ensure that the power wire is fused at the point where it is connected to the vehicle’s battery. Failure to do so can result in damage to the vehicle if a short circuit develops between the vehicle connection point and the product.

⚠ WARNING: This symbol with “WARNING” is intended to alert the user to the presence of important operating and maintenance (servicing) instructions in the literature accompanying the product.

⚠ CAUTION: This symbol with “CAUTION” is intended to alert the user to the presence of important operating and maintenance (servicing) instructions in the literature accompanying the product.

FEATURES

- Reliable and Efficient Class-D Circuit Design
- Surface Mount Component Technology
- Direct Insert Power and Speaker Terminals
- Protection and Clip LED Light Status Indicators
- Short, Thermal, and Under / Over Voltage Protection
- DC Offset Auto Turn On

PACKAGE CONTENTS

- (1) RTX Series Amplifier
- (1) EBC Remote Knob (Not Included with RTX1600.4 Model)
- (1) Manual
- (4) Mounting Screws
- (2) Allen Wrenches (3) for RTX3000.1



CONTROL FUNCTIONS

1. Gain Control - The gain control matches the input sensitivity of the amplifier to the source unit being used. The operating range is 300mv to 10V.
2. RCA Inputs - The RCA inputs accept signal from either low-level (RCA) or high-level (speaker) inputs up to 10V. Source units need a minimum 300mV output for proper operation of the amplifier.
3. Power / Protect LED - The Power / Protect LED illuminates blue when the amplifier is powered on and operating in the normal battery voltage range. The under / over voltage protection activates if the battery voltage drops below 9V, or exceeds 16.5V, and the LED turns off.

When the short circuit or overload protection is activated, the LED will remain illuminated blue, but the output of the amplifier channel with the fault condition is muted. The short / fault condition must be corrected for the amplifier to resume normal operation.

When the thermal protection is activated, the LED illuminates red and the output is muted. Once the amplifier has cooled to a safe operating temperature, and the LED returns to blue and the amplifier will resume normal operation.

If the LED remains illuminated red after the amplifier has cooled to a safe operating temperature, an internal fault has been detected and the amplifier requires warranty service.

4. Clip LED - The Clip LED is used to set the amplifier gain. The LED will illuminate blue as a visual indicator of when the mono channel or pair of channels have reached the maximum unclipped output level.
5. X-Over Mode and Frequency Control (RTX1600.4) - These controls are used to adjust the frequencies played by the amplifier. Use the switch to select Low Pass, Full Range, or High Pass. In LP or HP mode, the crossover frequency is variable between 40Hz and 300Hz. When the X10 switch is pressed, the crossover frequency range is adjustable between 400Hz and 3kHz.
6. Input Mode Switch (RTX1600.4) - This switch is used to select 2-channel or 4-channel modes based on the number of RCA outputs from the source unit.
7. External Bass Control (EBC) Port (RTX3000.1) - This port connects to the included MTX EBC to remotely control the output level of the amplifier.
8. Bass Boost (RTX3000.1) - This control is used to adjust the Bass Boost level from 0 - 12dB. The Bass Boost frequency is centered at 45Hz.
9. Subsonic Filter (RTX3000.1) - This control is used to filter out unwanted low frequencies from 10Hz (Off) to 55Hz. This is used more often with vented subwoofer enclosures, but some sealed enclosures can benefit from this as well.
10. Low Pass X-Over Frequency Control (RTX3000.1) - This control is used to adjust the Low Pass crossover frequency. The crossover frequency is variable between 50Hz and 250Hz for subwoofer channels.
11. Speaker Terminals (+ / -) - These terminals are connected directly to the speakers / subwoofers. RTX1600.4 will accept up to 10 AWG speaker cable. RTX3000.1 will accept up to 4 AWG speaker cable.
12. Power Terminal (+12V) - This terminal is connected with a power cable and inline fuse or circuit breaker directly to the positive terminal of the vehicle's battery. RTX amplifiers will accept up to 1/0 AWG power cable.

13. Remote Terminal - This terminal is connected to the "remote" wire from the source unit and is used to turn the amplifier on when +12V is applied. RTX amplifiers also feature automatic turn-on mode that detects DC offset voltage on the RCA inputs when using high level (speaker) inputs. A remote wire is not needed when using the automatic turn-on feature.

14. Ground Terminal - This terminal is connected with a short ground cable directly to the chassis of the vehicle. The ground cable must be the equivalent gauge as the power cable. RTX amplifiers will accept up to 1/0 AWG ground cable.

15. Turn On Mode Switch (RTX3000.1) - This switch allows you to select your preferred mode of automatic turn-on. Select REM to use the remote turn on lead from the source unit. Select DC to detect the DC offset voltage from the High-Level speaker outputs when the source unit has been turned on.

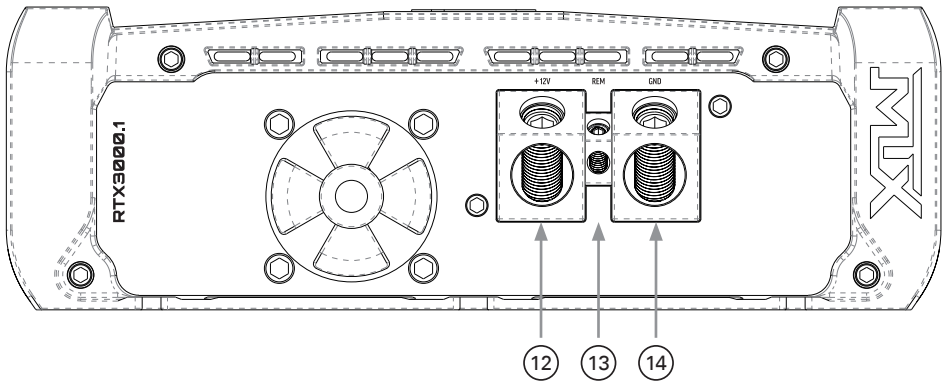
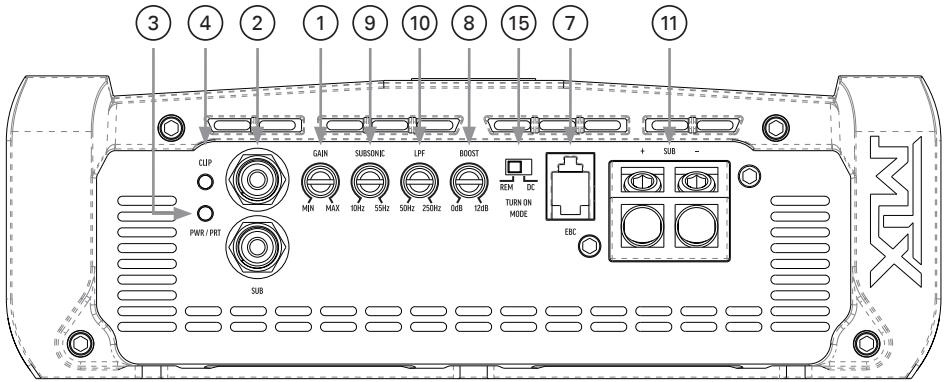

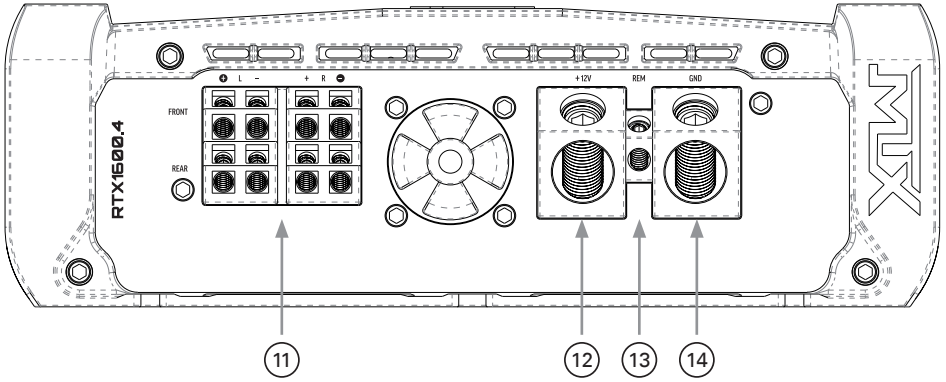
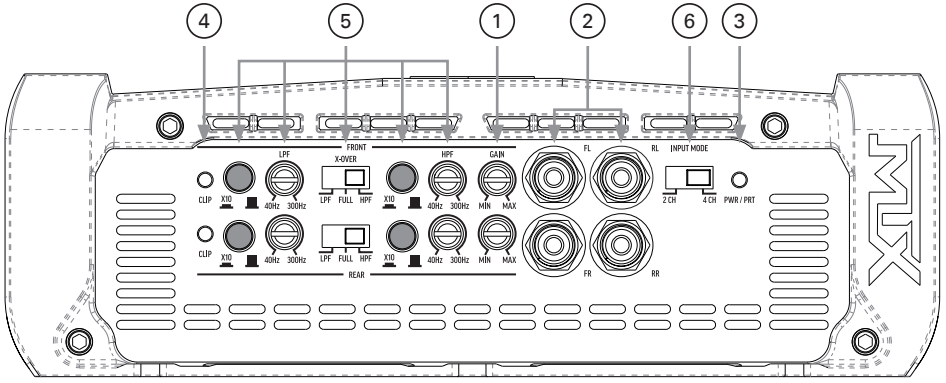

INSTALLATION

MTX recommends your new RTX Series amplifier be installed by an Authorized MTX Dealer. Any deviation from specified installation instructions can cause serious damage to the amplifier, speakers and / or vehicle's electrical system. Damage caused from improper installation is NOT covered under warranty. Please verify all connections prior to system turn on!

1. Disconnect the vehicle's negative battery cable and secure it away from the battery terminals to prevent it from being reconnected accidentally when routing the amplifier power cables.
2. Determine the mounting place for your amplifier. Keep in mind there should be sufficient air flow for proper cooling. Mark the mounting holes using the amplifier as a template. Before drilling or installing mounting screws, make sure all vehicle wires, gas lines, brake lines, and gas tank are clear and will not interfere with the amplifier installation. Drill mounting holes (where applicable) and install the amplifier using supplied mounting screws.
3. Install a positive (+) power cable from the vehicle's battery through the firewall using a grommet or firewall bushing to avoid cable damage from sharp edges of the firewall. Run the cable through the interior of the vehicle and connect it to the amplifier's (+12V) terminal. Do not connect to the battery at this time.
4. Install a circuit breaker or fuse holder on the power cable within 18" of the battery. This effectively lowers the risk of severe damage to you or your vehicle in case of a short circuit or accident. Make sure the circuit breaker is switched off or the fuse is taken out of the fuse holder until all connections are made. Now connect the positive power cable to the positive battery terminal.

Note: Use equivalent gauge wire for both power and ground connections.

5. Grounding - Locate a proper ground point on the vehicle's chassis and remove all paint, dirt or debris to reveal a bare metal surface. Attach the ground wire to that contact point. Connect the opposite end of the ground wire to the amplifier's (GND) terminal.
6. Connect a Remote Turn-on wire from the source unit to the amplifier's (REM) terminal. If using a factory source unit that does not have a remote turn-on output, the amplifier will turn on automatically when it detects DC Voltage on the Left (Upper) RCA inputs connected to high level (speaker) outputs.
7. Connect the signal cables from the source unit to the amplifier RCA inputs.
 - When using a source unit with low-level (RCA) outputs, use high quality RCA cable(s) to connect directly to the amplifier RCA inputs.
 - When using a source unit with high level (speaker) outputs, use an RCA to speaker level adapter, or splice speaker wires directly to RCA cable(s) and connect to the amplifier RCA inputs.
 - For source units with high level output greater than 10V, a separate high to low level converter is required.
8. Connect your speakers to your amplifier's speaker terminals using the appropriate gauge speaker wire. See Wiring Diagrams on page 11 for minimum speaker impedance requirements per model.
9. Double check all previous installation steps, in particular, wiring and component connections. Once verified, reconnect the vehicle's negative battery cable, turn the circuit breaker on or place the fuse in the fuse holder.

10. Crossover and Tone Control Adjustment

RTX3000.1:

A. Adjust the Low Pass Filter (LPF)

- Turn the LPF control to the desired cutoff frequency for the subwoofer(s) being driven.
- Frequencies above the selected cutoff frequency will be filtered out.
- 60Hz-80Hz is a good starting point for subwoofers and can be adjusted to achieve the desired frequency response.

B. Adjust the Subsonic Filter (SUBSONIC)

- Turn the SUBSONIC control to the desired cutoff frequency for the subwoofer(s) being driven.
- Frequencies below the selected cutoff frequency will be filtered out.
- 20Hz-30Hz is a good starting point for most subwoofers and can be adjusted to achieve the desired frequency response.

C. Adjust the Bass Boost (BOOST)

Note: Bass Boost is subject to personal preference, and is not needed for all subwoofer applications.

- It is recommended to perform initial system tuning with Bass Boost turned all the way down.
- If additional Bass Boost is desired, adjust the Bass Boost control clockwise to the desired output level.

RTX1600.4:

A. Select the desired crossover mode for each pair of channels based on the application and type of speakers being driven using the X-OVER switch.

- HPF: High Pass Filter is used for Midrange Speakers, Coaxials, & Component Systems.
- LPF: Low Pass Filter is used for Subwoofers.
- FULL: Defeats internal crossovers for full bandwidth audio signal.

Note: Each pair of amplifier channels has a dedicated crossover that can be set to either HPF, LPF, or FULL mode. When HPF or LPF mode is selected, use only the corresponding HPF or LPF control to adjust the crossover frequency.

B. Adjust the High Pass Filter (HPF)

- Turn the HPF control to the desired cutoff frequency for the speakers being driven.
- Frequencies below the selected cutoff frequency will be filtered out.
- 80Hz-100Hz is a good starting point for speakers and can be adjusted to achieve the desired frequency response.

C. Adjust the Low Pass Filter (LPF)

- Turn the LPF control to the desired cutoff frequency for the subwoofers being driven.
- Frequencies above the selected cutoff frequency will be filtered out.
- 60-80Hz is a good starting point for subwoofers and can be adjusted to achieve the desired frequency response.

11. Gain Adjustment

A. Turn the GAIN control(s) on the amplifier all the way down (counter clockwise).

B. Set all Bass, Midrange, and Treble controls on the source unit to flat. If using the EBC on a sub channel, make sure it is plugged in and the level is turned to the maximum position.

C. Select a familiar music track with high quality recording, then turn up the volume control on the source unit to approximately 3/4 of maximum.

D. Slowly turn the GAIN control on the amplifier up (clockwise) and stop when the Clip LED illuminates solid blue.

E. For amplifier channels driving subwoofers, the gain is set, and no additional adjustments are needed.

F. For amplifier channels driving speakers, adjust the GAIN control down slightly and stop right when the Clip LED turns off.

G. Repeat Steps A through F for each pair of amplifier channels and / or mono channel.

Note: The amplifier is now calibrated to the output of the source unit, and the optimal gain level has been set. Any increase to the gain level(s) beyond this set point will result in audible distortion and possible speaker damage.

12. Final Tuning - Once the optimal gain level has been set for all amplifier channels in Step 11, any further adjustments for system balance should be made by turning the gain level(s) down. Fine tuning of the crossover frequencies and tone controls may be needed to eliminate distortion and achieve the desired frequency response. It is highly recommended to sample different music selections and make incremental adjustments to achieve the desired system performance. If large adjustments are made to crossover settings, tone controls, or source unit EQ settings, it may be necessary to re-adjust the gain level following the process outlined in step 11 above.

WIRING

RTX3000.1

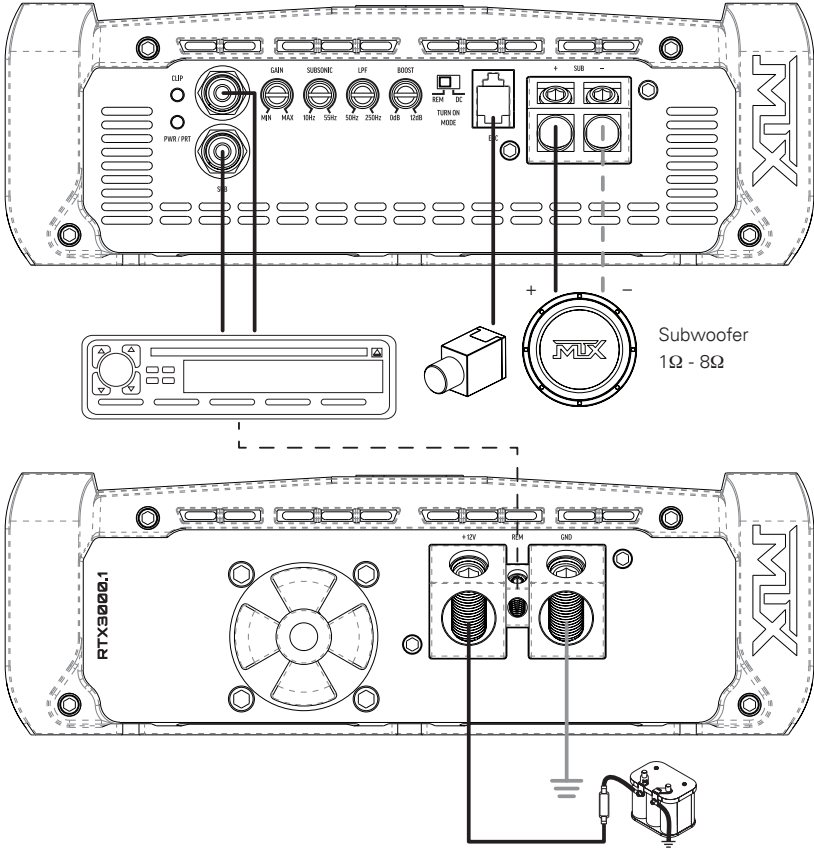

DIMENSIONS

<i>Model</i>	<i>Height (A)</i>	<i>Width (B)</i>	<i>Depth (C)</i>
RTX3000.1	2 11/16" (67mm)	13 5/8" (346mm)	8 1/4" (208mm)
RTX1600.4	2 11/16" (67mm)	13 5/8" (346mm)	8 1/4" (208mm)

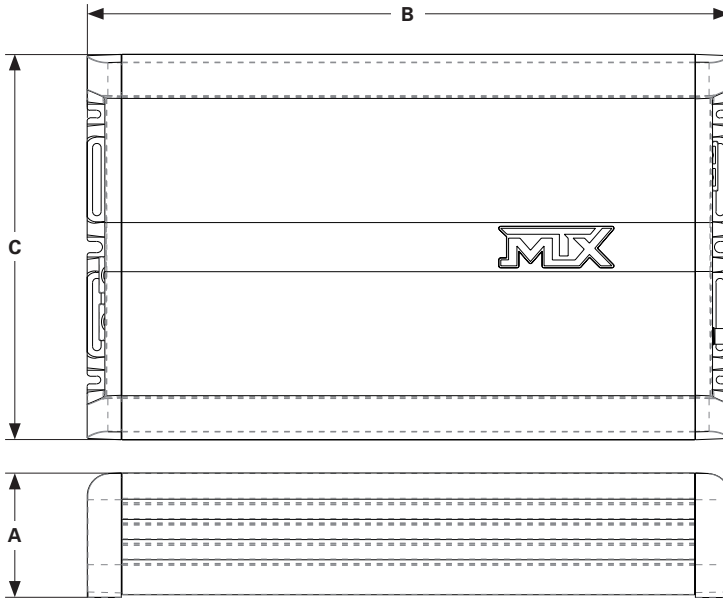

SPECIFICATIONS

<i>Model</i>	RTX3000.1	RTX1600.4
<i>Circuit Topology</i>	Mono Class-D	Full Range Class-D
<i>RMS Power Output at 1Ω</i>	3000W	N/A
<i>RMS Power Output at 2Ω</i>	2000W	400W x 4CH
<i>RMS Power Output at 4Ω</i>	1000W	250W x 4CH
<i>RMS Power Output at 4Ω Bridged</i>	N/A	800W x 2CH
<i>Total Harmonic Distortion</i>	<0.3%	<0.3%
<i>Signal to Noise Ratio</i>	>98dB	>95dB
<i>Input Sensitivity</i>	10V - 300mV	10V - 300mV
<i>Crossover Range</i>	50Hz - 250Hz	40Hz - 300Hz (x1) 400Hz - 3kHz (x10)
<i>Frequency Response</i>	20Hz - 250Hz	20Hz - 20kHz
<i>Bass Boost</i>	0dB - 12dB	N/A
<i>Subsonic Filter</i>	10Hz - 55Hz	N/A
<i>EBC Remote Knob</i>	Yes	No
<i>Recommended External Fuse Rating</i>	250A - 300A	150A - 200A
<i>Recommended Power / Ground Cable</i>	1/0 AWG	1/0 AWG

MITEK WARRANTY

MiTek Mobile products (including, but not limited to: MTX, Coustic, Streetwires, Xtant, BassSlammer, and Thunder Marine) purchased in the USA from an AUTHORIZED MITEK DEALER are guaranteed against defects in material and workmanship for two years. The warranty period begins the day the product is purchased by the end user, and this warranty is limited to the original retail purchaser of product. Products found to be defective during the warranty period will be repaired or replaced with equivalent product by MiTek at no charge. This warranty is void if it is determined that unauthorized parties have attempted repairs or alterations of any nature, and the warranty does not extend to cosmetics or finish. MiTek disclaims any liability for other incurred or consequential damages resulting from product defects. MiTek's total liability will not exceed the purchase price of the product.

We're here to help! If you experience an issue with any of our products, please contact our customer service technical line at 1-800-CALL-MTX to help troubleshoot your issue. If after speaking with our technical experts it is determined that your product is defective, the technician will provide you with a Return Authorization number and all relevant details you'll need to process your claim quickly.

Let's Get Social
mtx.com



Like, Follow, & Subscribe

© 2025 MiTek Corporation. All rights reserved. MTX is a trademark of MiTek Corporation. All other trademarks are property of their respective owners. Designed and Engineered in the U.S.A.

Due to continual product development, all specifications are subject to change without notice.

MTX Audio, 4545 East Baseline Rd. Phoenix, AZ 85042 U.S.A. 1-800-225-5689

MTX007989 RevC 2/25 • AW0016480 • 1-23129