

MSX Blueprint[®] series

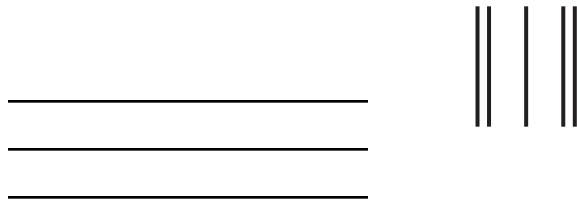

FIRST
CLASS
STAMP
HERE

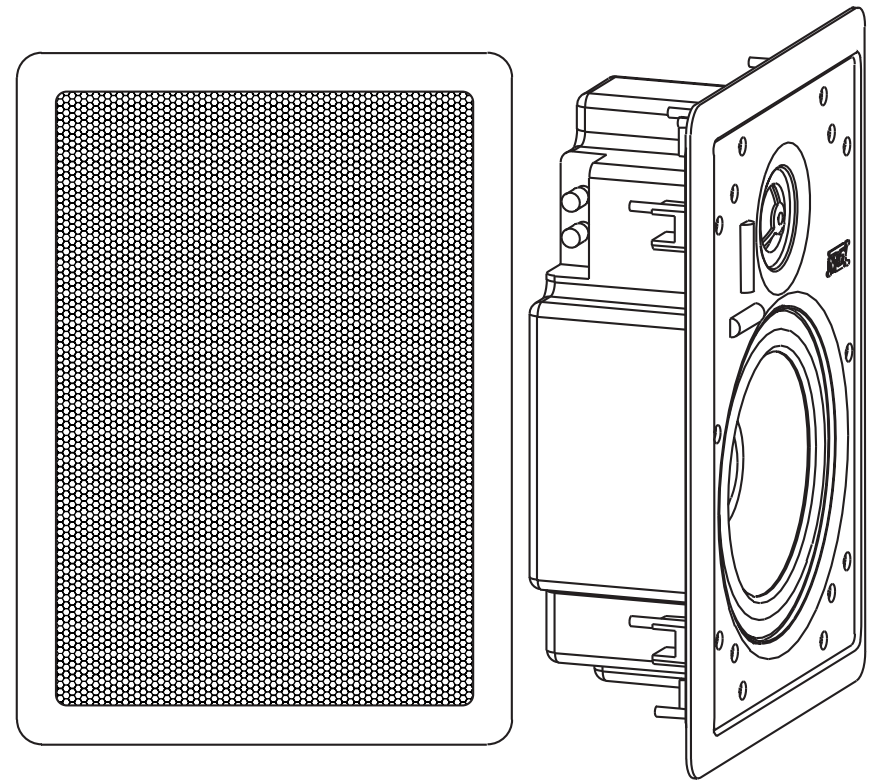

MODEL 620WE

IN-WALL ENCLOSED LOUDSPEAKER OWNERS MANUAL

MSX
4545 E BASELINE RD
PHOENIX AZ 85040-6400



CONGRATULATIONS

We appreciate your choice of MTX In-Wall Loudspeakers. Properly installed and operated, MTX In-Wall Loudspeakers should provide years of worry free listening pleasure. It's important that you follow each step in this guide carefully to insure proper installation. If you have any questions regarding MTX In-Wall Loudspeakers, please call us at 1-800-223-5266.

SPECIFICATIONS

Frequency Response	62-20kHz
Impedance	4 Ohms
Nom. Power Handling	55 Watts
Peak Power Handling	180 Watts
Sensitivity	82dB@1W/1m
Woofers Diameter	6-1/2"
Tweeter	1" Soft Dome
Mounting Depth	3.709"

FEATURES

The Model 620WE in-wall enclosed loudspeaker is a unique design unlike any other before it. It allows you to bring concert-quality sound to virtually any area of your home that may have been previously off-limits because of building code restrictions or weather conditions.

The Model 620WE utilizes its mounting wings to mount into a wall like conventional in-wall speakers, while incorporating an integral enclosure to provide a vapor barrier between you and the outside world.

The long excursion, high performance woofer was designed specifically to work with its integral enclosure to insure deep, accurate bass. While the soft dome tweeter perfectly complements the woofer with its sweet sound and well-controlled off-axis frequency response. The tweeter is also designed to pivot which allows you to "aim" the high frequencies.

All of the Model 620WE components have been manufactured with high quality, weather resistant materials. This completes the Model 620WE's package of versatility, performance and durability.

PAINTING YOUR MTX IN-WALLS

MTX In-Walls are designed to accept all types of interior and exterior paints. Spray or roller application should provide excellent results. A paint shield is included with all Blueprint Series In-Walls to protect the speakers during the painting process.

WARRANTY

MTX Blueprint Series In-Wall Loudspeakers are guaranteed against defects in parts and workmanship for a period of ten (10) years from the date of purchase. Speakers found defective during that period will be repaired by MTX without charge for parts.

This warranty is void if it is determined that unauthorized parties have attempted repairs or alterations of any nature. Before assuming that a defect is present in the loudspeakers, be certain that all associated equipment is operating properly.

If a defect is present, your authorized MTX dealer may be able to effect repairs. If not, you are responsible for providing transportation to the factory. Your MTX dealer can recommend the safest method of transportation. Proof of purchase is required when requesting service, so please retain your sales slip.

Specifications subject to change without notice.

(Cut out on dotted line and mail to address on reverse side.)

WARRANTY REGISTRATION

To register your purchase and insure your investment, please fill out and return this card.

NAME _____ AGE _____

ADDRESS _____

MODEL PURCHASED: MODEL 620WE

DATE PURCHASED _____

DEALER NAME _____

PURPOSE: Main Music Listening Background Video/surround

Other _____

ROOM(S) INSTALLED _____

INSTALLED BY _____

HOW DID YOU FIRST LEARN OF MTX IN-WALLS?

Dealer Friend Magazine Radio Newspaper Other

COMMENTS _____

OTHER HOME AUDIO PRODUCTS FROM MTX

MTX offers a wide assortment of audio components. Ranging from in-ceiling speakers to amplifiers to accessories. Each component is value engineered and must meet strict quality control standards before it becomes part of the MTX product line.

Listed below you will find a sampling of components available from your authorized MTX dealer.

LPS-600

Speaker/Amplifier Selector

Accommodates up to 6 pair of speakers

Handles up to 250 watts/channel continuous (RMS)

Impedance Protection Circuitry

Accommodates up to 14 gauge wire

MODEL MP42

Multi-Purpose Loudspeaker

Two 4" Woofers, with 1/2" Balanced Dome Tweeter

50 Watts RMS/200 Watts Total Power Handling

Magnetically shielded, weather resistant

Sleek, Euro-style design

Available in white or black

12.6" x 4.8" x 4.9"

PS15

15" Powered Subwoofer System

200 Watt Class D Switching Power Amplifier

Infrared Remote Control for Volume Function

Magnetically Shielded, Downfiring Subwoofer in small enclosure

Signal Sensing Auto Turn On

Red LED Clipping Indicator

Speaker and Line Level Inputs

Continuously variable 50Hz to 150Hz, 24dB/Octave Crossover

Frequency Response 30Hz - 150Hz

17.2" H x 17" W x 20.25" D

LOUDSPEAKER PLACEMENT

Blueprint Series Loudspeakers are designed to work within any interior decorating scheme. They can be installed in virtually any location where flush mounting is possible. To maximize their sound performance however certain guidelines should be followed. For the best stereo reproduction the two loudspeakers should be placed an equal distance from your listening position and separated so that the angle between them, at the listening position, is between 40 and 60 degrees.

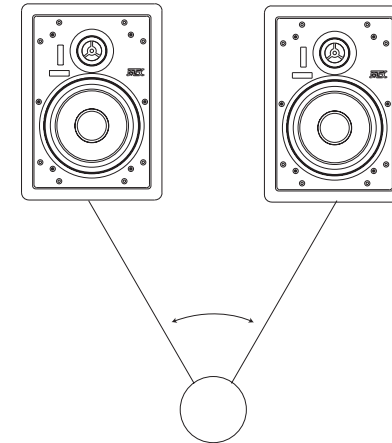

For best stereo imaging, we recommend that the units be placed so that the tweeters are as close as possible to the ear level of a seated listener. As this is not always possible in keeping with aesthetic design of a particular room, the Model 620WE loudspeaker is designed with a pivoting tweeter which rotates to allow you to "aim" the high frequencies toward the listening position.

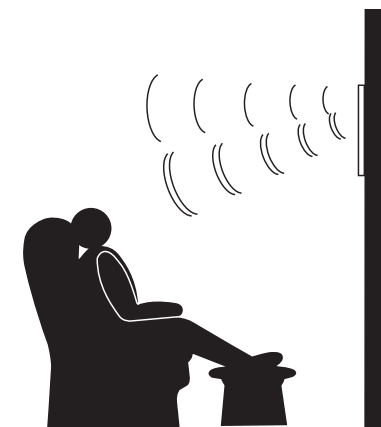

(Normal Dispersion

((Dispersion After Tweeter Adjustment

STEP 1

Using a stud finder (available at low cost at most hardware stores) or other accurate method, locate center point between two studs and mark. Using template provided, trace hole pattern on surface of wall.

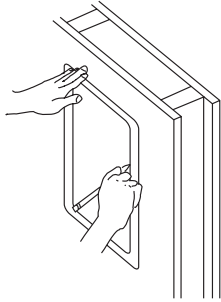

STEP 2

Using a sabre saw, keyhole saw or very sharp utility knife, cut hole in wall, following traced pattern.

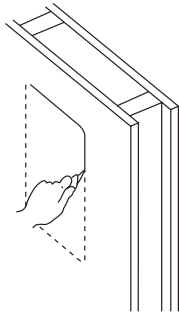

STEP 3

Run loudspeaker wires to sound source location. There are several methods you can use to accomplish wiring, depending on the construction characteristics of the room or house. You can add a professional touch to your installation by using a speaker terminal plate at the source location. Leave sufficient amount of wire at speaker location (8 to 10 inches) to complete connection.

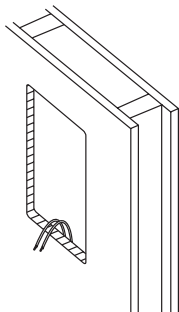

STEP 4

Attach loudspeakers wires to speaker terminals, observing correct polarity (positive to positive and negative to negative). Insert the speaker into the mounting hole. Be careful not to pinch the loudspeaker wires in the process. using the integral bubble levels located on the baffle, align the speaker's frame either horizontally or vertically. Once you are satisfied with the speaker's location, tighten the eight mounting wings located near each corner of the frame using a phillips screwdriver. The mounting wings are designed to swing into position when you start tightening. *Note: the phillips head screws are for tightening the mounting wings. The torx head screws are for the enclosure which should not be tightened or loosened.*

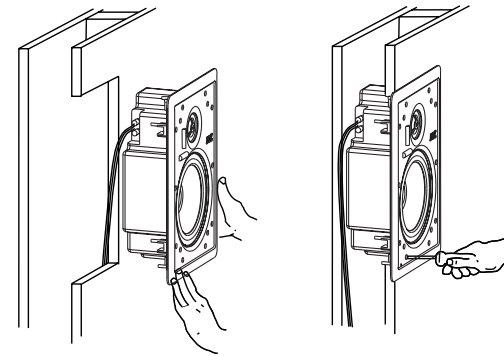

STEP 5

After speaker panel is secured tightly, test for sound.

STEP 6

When you are satisfied the speaker is operational, "aim" the tweeter, and affix grill. As grill is designed for a snug fit, you'll need to position one edge into the slot first, and press or squeeze around perimeter of the grill, while pushing the leading edge into the grill slot.

